



PROINAD92, S.L.
ENGINEERING SOLUTIONS



BASKET STRAINERS

(QUICK OPENING)

DN 50 - 200 PN10, PN16 & ANSI 150

Carbon Steel & Stainless Steel



BASKET STRAINERS



BASKET STRAINERS

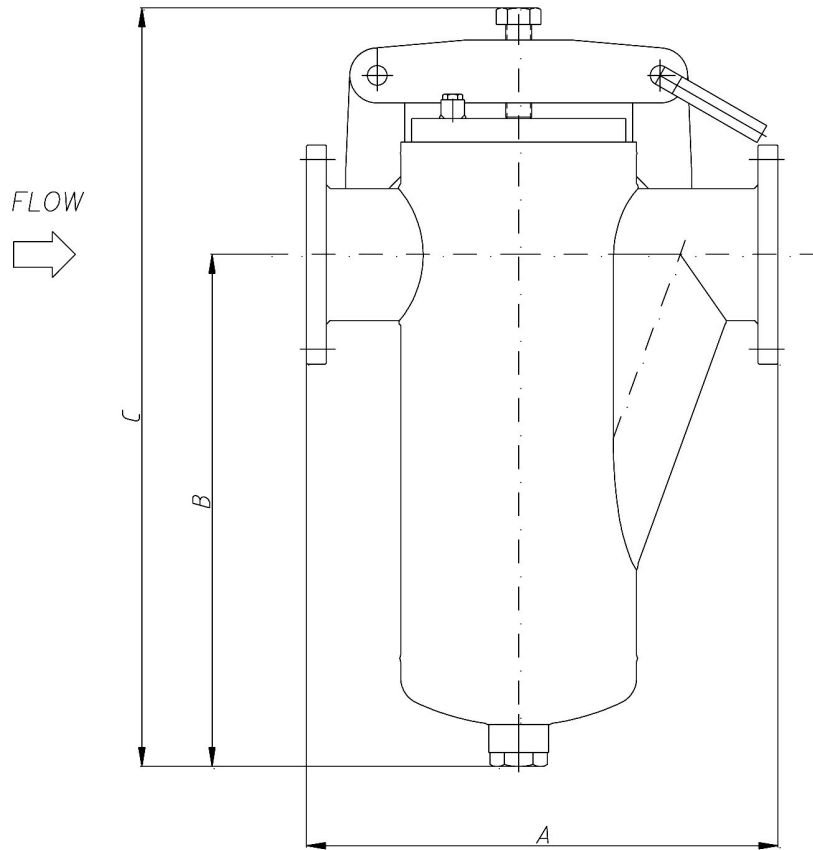

Standard screen: Perforation: 1.5 mm Thickness: 0.5 mm

DN	A	B	C	Drain	Vent	Rel. Areas
50	300	340	490	1"	----	1:5.49
65	350	370	550	1"	----	1:4.33
80	375	409	625	1"	----	1:3.73
100	440	457	685	1"	----	1:3.31
125	525	580	730	1 1/2"	1/2"	1:2.61
150	600	670	910	1 1/2"	1/2"	1:2.83
200	800	810	1080	1 1/2"	1/2"	1:2.75
250	900	870	1250	2"	3/4"	1:2.67
300	950	930	1360	2"	3/4"	1:2.63
350	1050	1150	1600	2"	1"	1:2.60
400	1150	1180	1680	2"	1"	1:2.28